



NEW
Wheel & Steer Options
now available*





Removable Storage Bins
option to replace bins with a flat shelf



50kg capacity
fully height adjustable

Height Adjustable Cargo Shelf

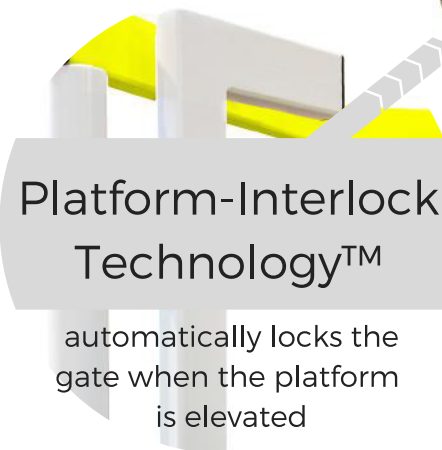

Platform-Interlock Technology™
automatically locks the gate when the platform is elevated



Simple Control Unit



Auto-Elevation Braking



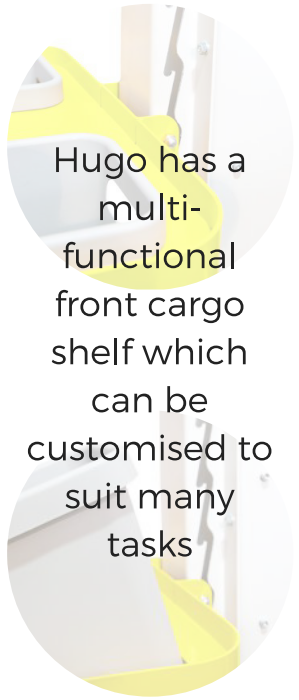

Hugo has a multi-functional front cargo shelf which can be customised to suit many tasks



Flat shelf in stainless steel for food environments



Flat shelf in acrylic for libraries and FM

Custom shelf with non-slip surface for archive boxes

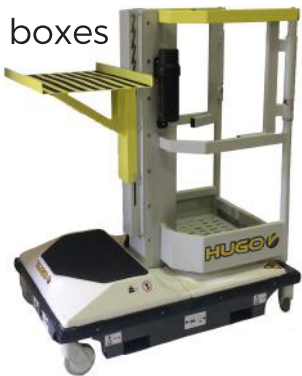

Perfect for stock-picking or stock-taking



Tool bins for FM work, holding tools and cleaning materials

Hugo Lift is PERFECT for:

- Manufacturing
- Hospitals
- Libraries & Archives
- Schools & Universities
- Facilities Management
- Food & Beverage Production

Technical Data		HUGO2	HUGO4
B	Maximum platform height	2.2m	2.2m
A	Maximum working height	4.2m	4.2m
G	Platform entry height	0.39m	0.39m
E	Overall width	0.73m	0.73m
F	Overall length	1.17m	1.13m
D	Overall height (stowed)	1.4m	1.4m
C	Maximum cargo shelf height	3.28m	3.28m
I	Minimum cargo shelf height	0.99m	0.99m
H	Cargo shelf adjustment	0.38m	0.38m
	Operator compartment capacity	120kg (1 person + tools)	120kg (1 person + tools)
	Cargo shelf capacity	50kg	50kg
	Ground shelf capacity	50kg	50kg
	Wind speed rating	0 m/s (indoor use only)	0 m/s (indoor use only)
	Maximum wheel loading	120kg	120kg
	Total transport weight*	258kg	250kg
	Power*	12V 52A Gel Battery	12V 52A Gel Battery
	Mains power supply for battery charging	110/220V self-seeking	110/220V self-seeking
	Wheels and Steer system	2 x fixed and 2 x swivel castors	4Glide wheel and steer system gives 4-wheel steer. 1 wheel has a directional lock option for easy turning
	Brakes	1 foot-operated lever applies rear brakes. Front brakes automatically applied on elevation	Auto elevation braking applies the brakes when the platform is raised, even if the operator forgets.

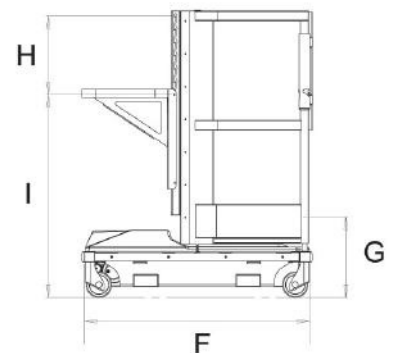
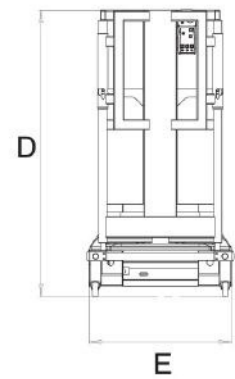
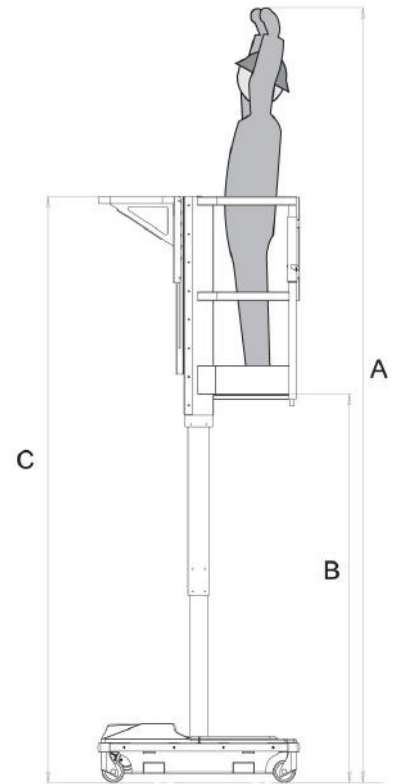

**OPTIONAL
*Battery+ Pack**
Double your battery pack capacity:
adds 20kg to overall weight

